



Modular Cooking Range Line 700XP Electric Hob Cooking Top 400 mm

ITEM # _____

MODEL # _____

NAME # _____

SIS # _____

AIA # _____



371027 (E7HOED2000)

Half module electric hob cooking top

Short Form Specification

Item No.

High efficiency 5.3 kW infrared heating elements. Large flat cooking surface in mild steel allows for the use of a number of various sized pots and pans, all easily moved across the surface without lifting. Exterior panels in stainless steel with Scotch Brite finish. One piece pressed work top in 1.5 mm thick stainless steel. Right-angled side edges to allow flush-fitting junction between units.

Main Features

- 5.3 kW infrared heating elements can reach a maximum temperature of 400°C.
- Durable mild steel cooking plate, easy to clean.
- Various sizes of pans can be used at the same time due to large surface area with no intermediate sectors.
- Pans can easily be moved from one area to another without lifting.
- All major compartments located in front of unit for ease of maintenance.
- Top configuration allows installation on ambient base only (not possible to install on refrigerated nor freezer base).
- Suitable for countertop installation.

Construction

- All exterior panels in Stainless Steel with Scotch Brite finishing.
- One piece pressed 1.5 mm work top in Stainless steel.
- Model has right-angled side edges to allow flush fitting joints between units, eliminating gaps and possible dirt traps.
- IPx4 water protection.

Optional Accessories

- Junction sealing kit PNC 206086
- Support for bridge type installation, 800mm PNC 206137
- Support for bridge type installation, 1000mm PNC 206138
- Support for bridge type installation, 1200mm PNC 206139
- Support for bridge type installation, 1600mm PNC 206141
- Support for bridge type installation, 400mm PNC 206154
- Water column with swivel arm (water column extension not included) PNC 206289
- Water column extension for 700 line PNC 206291
- Chimney upstand, 400mm PNC 206303
- Right and left side handrails PNC 206307
- Chimney grid net, 400mm (700XP/900) PNC 206400
- Frontal handrail, 400mm PNC 216046
- Frontal handrail, 800mm PNC 216047
- Frontal handrail, 1200mm PNC 216049
- Frontal handrail, 1600mm PNC 216050
- Large handrail - portioning shelf, 400mm PNC 216185
- Large handrail - portioning shelf, 800mm PNC 216186

APPROVAL: _____



Experience the Excellence
www.electroluxprofessional.com
ELUX_EMAIL



Electrolux
PROFESSIONAL

**Modular Cooking Range Line
700XP Electric Hob Cooking Top
400 mm**

- 2 side covering panels for top appliances PNC 216277
- 2 baskets 170x220 for pasta cookers PNC 921610



**Modular Cooking Range Line
700XP Electric Hob Cooking Top 400 mm**

The company reserves the right to make modifications to the products without prior notice. All information correct at time of printing.

2026.06.17

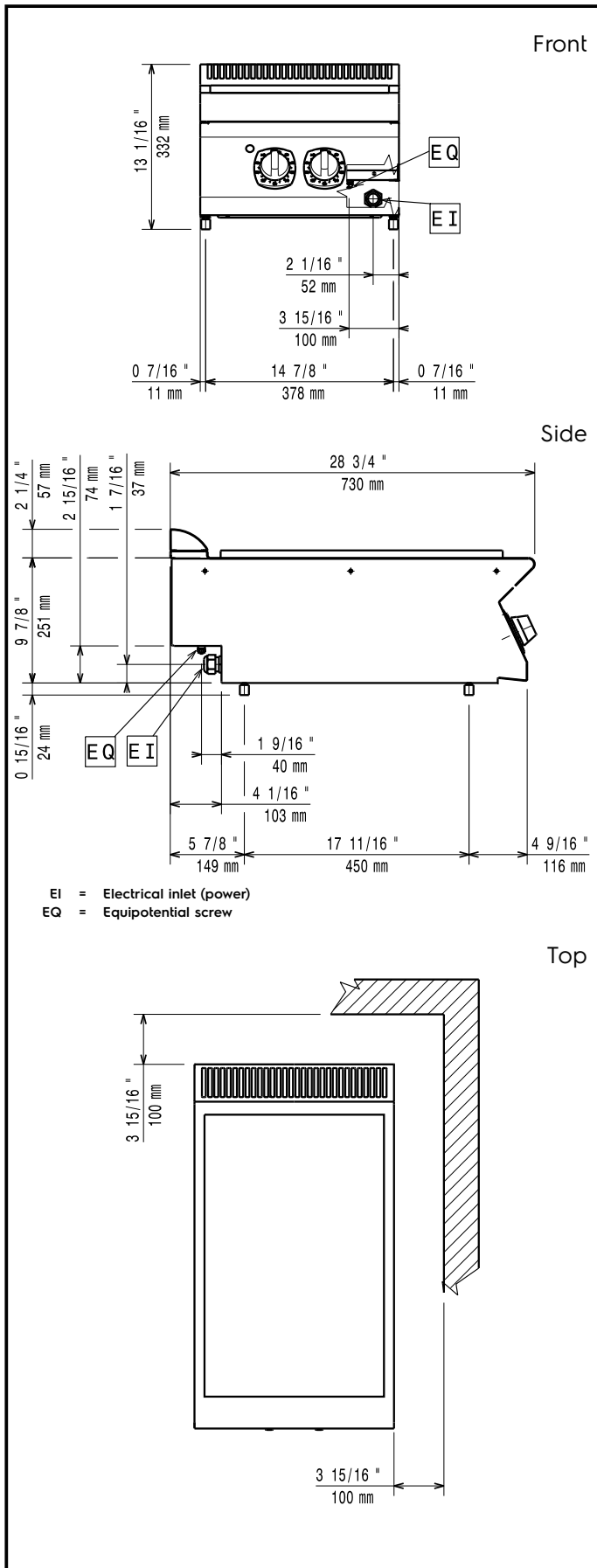

Electric

Supply voltage:	380-400 V/3N ph/50/60 Hz
Rated amps:	0 A
Total Watts:	5 kW

Key Information:

If appliance is set up or next to or against temperature sensitive furniture or similar, a safety gap of approximately 150 mm should be maintained or some form of heat insulation fitted.

External dimensions, Width:	400 mm
External dimensions, Depth:	730 mm
External dimensions, Height:	250 mm
Net weight:	47 kg
Shipping weight:	42 kg
Shipping height:	530 mm
Shipping width:	460 mm
Shipping depth:	820 mm
Shipping volume:	0.2 m ³
[NOT TRANSLATED]	EST72
Solid top usable surface (width):	360 mm
Solid top usable surface (depth):	565 mm